

LW177S SINGLE ZONE WINE COOLER



LANBO INTERNATIONAL INC.

 601 S Dupont Ave, Ontario, CA 91761

 Website: www.lanboappliances.com  TEL: 909-468-1448

 E-mail: service@lanboappliances.com



ABOUT LANBO

Lanbo is a global manufacturer and supplier of innovative home appliances with cutting edge technology and energy efficiency. The Lanbo Series wine and beverage coolers are designed with the customer in mind looking for timeless elegance, user-friendly features and built-in or standalone installation comparable to luxury brands, at an affordable price. Wine coolers and beverage centers that provide greater living, convenience and comfort, while contributing to the preservation of our planet. With Lanbo, you can expect quality, satisfaction and innovation, as we continuously work to improve our operations and our people, making our products safe, efficient and ethical.





LW177S 24 Inch Single Zone Wine Cooler

Our Lanbo LW177S single zone wine fridge features an impressive 165 bottle storage capacity and double pane insulated glass for optimized storage of your favorite wines. A digital easy to read LED temperature display ensures your wine collection is stored and served at the appropriate temperature. Adjustable temperature ranges allow you to select a proper, customized storage and serving temperature for red and white wines. Offering true design and installation versatility this is the perfect wine cooler for your kitchen pantry, wine cellar or family entertainment area.



MATURE CRAFTSMANSHIP GIVES A BETTER EXPERIENCE



Stainless Steel Curved Handle

Ergonomically designed to provide a comfortable door opening and closing experience



Stainless Steel Trimmed Glass Door and Strong Door Seal

The solid and reliable door body ensures stable temperature and humidity inside the unit



Double Layer Glass

The double-layers tempered glass window offers protection from harmful UV rays while still providing a full view of your collection



Safety Lock

Factory installed keyed door lock provides added security for your valuable wine collection

HIGH-END INTERIOR DESIGN ACHIEVES A PERFECT STORAGE ENVIRONMENT



Solid Beech Wood Shelf

The standard beech wood shelf is more convenient to disassemble and replace, it is more resilient and bears more stable, no peculiar smell, and will not affect the quality of wine



Smooth Rails And Sturdy Stand

The silky and smooth pull-out shelf has strong load-bearing capacity, the LW177S can carry the weight of up to 165 bottles of wine



LED Ambient Light

Soft white LED lights illuminate the interior of the wine cooler at the touch of a button, allowing you to read the label in the dark. Save energy with automatic shut off after 10 minutes of no use



Digital Control Panel

This wine cooler refrigerator features an adjustable temperature range that can be set 41° F to 64° F which provides ideal storing conditions for reds and whites





Front Venting

The front ventilation system allows the heat to escape in front of the wine cooler so it can be installed in between cabinets



Fan Cooling Circulation and Carbon Filter

The air-cooled system circulates cool air through the box and the activated carbon filter provides cleaner air, creating the best storage environment



High-Efficiency Compressor

The high quality, energy saving, quiet compressor provides vibration free cooling. Advanced cooling technology ensures even air distribution throughout the cabinet



Adjustable Support Feet

Four adjustable feet can be adjusted to suit cabinet height and uneven floors



Doors

Door Handle Design	external
Door Swing Orientation	left
Number of Doors	1
Door Material	tempered glass
Door Material Details	tinted double pane
Door Color/Finish	stainless steel
Door Opening Degree to Slide out Shelves	>90°
UV Resistant	Yes
Door Reversible	Yes

Temperature Specification

Temperature Zones	single zone
Overall Minimum Temperature	41 degrees F
Overall Maximum Temperature	64 degrees F
Wine Bottle Capacity	165
Temperature Display Type	touch screen

Shelves

Adjustable Shelves to different heights	No	Full shelf size (Width x Depth x Height)	18.8x21.3x1.0inches
Number of Shelves	14 full shelves + 1 half shelf		
Shelve Material	beech wood	Half shelf size (Width x Depth x Height)	18.8x12.8x1.0inches
Shelves slide out degree	75%		

Unit Dimension and Weight	
Overall Height - Top to Bottom	71.3 inches
Overall Width - Side to Side	23.4 inches
Overall Depth - Front to Back	28.4 inches
Depth - Excluding Handles	26.8 inches
Interior Height - Top to Bottom	63.4 inches
Interior Width - Side to Side	20.5 inches
Interior Depth - Front to Back	21.4 inches
Door Height - Top to Bottom	66.5 inches
Door Width - Side to Side	23.4 inches
Door Depth - Front to Back	1.3 inches
Depth With Door Open at 90 Degrees	48.9 inches
Cutout Width - Side to Side	24.2 inches
Cutout Depth - Front to Back	28.0 inches
Cutout Height - Top to Bottom	71.1 inches
Overall Product Weight	216.1 Lbs
Net Weight	216.1 Lbs
Shipping Weight with Panel	231.5 Lbs
Shipping Height - Top to Bottom with Panel	77.7 inches
Shipping Width - Side to Side	26.0 inches
Shipping Depth - Front to Back	30.3 inches

THE SMALLEST SPACE LEFT FOR INSTALLING

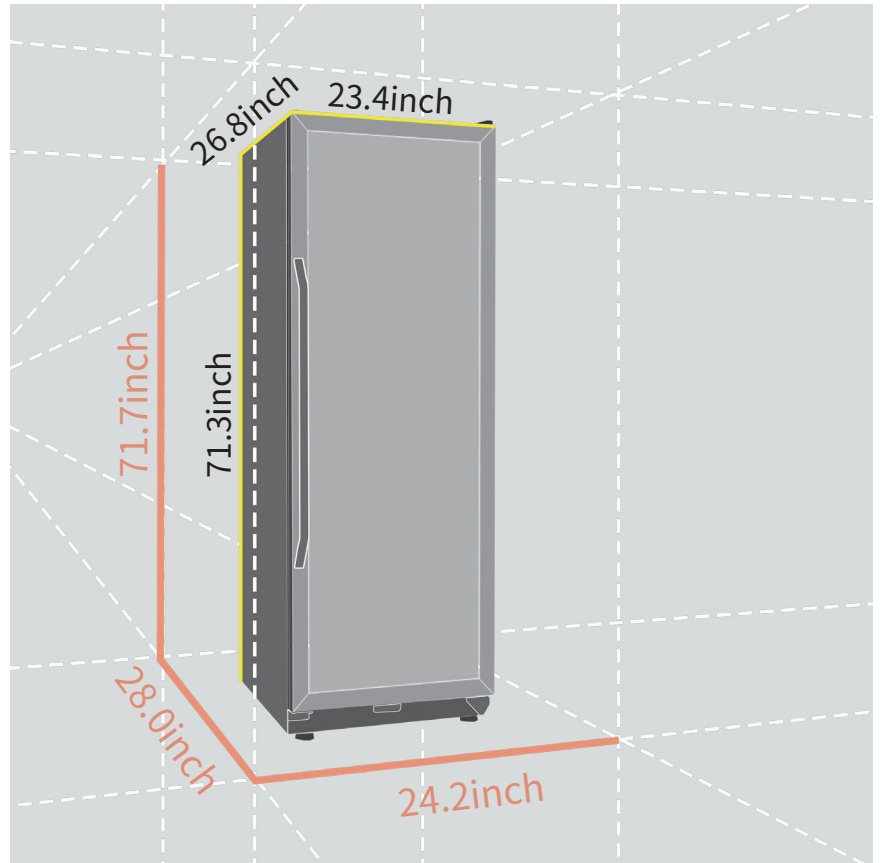

- Product dimensions: 23.4*23.6*33.9inch
- Suggested dimensions for built-in: 24.2*24.8*34.3inch
- The unit generates heat when it operates, most of it is released by the front venting
- Additional space is still required to complete the air circulation, and the installation space should be larger than the suggested dimensions to keep the machine running at optimum efficiency

Warranty	
Manufacturer Warranty (labor)	1 year
Manufacturer Warranty (parts)	1 year

Installation and Usage	
Installation Required	No
Tools Needed for Installation	No
Additional Parts Required	No
Supplier Intended and Approved Use	residential and commercial use
Outdoor Use	No
Product Care	wipe clean with a dry cloth
Undercounter	No

Each Box Contains	
LW177S Single Zone Wine Cooler	1 unit
User Manual	1 pc
Keys	2 pcs
Hinge cover	1 pc

Certifications Listings and Approvals	
ETL Listed	Yes
ISO 9001 Certified	Yes





LANBO

Your One-Stop Home Appliances Supplier

LANBO INTERNATIONAL INC.

 601 S Dupont Ave, Ontario, CA 91761

 Website: www.lanboappliances.com  TEL: 909-468-1448

 E-mail: service@lanboappliances.com