

# CIM010-80

# Commercial Ice Maker

## User Manual

SKU:CIM010-80BL-USZX

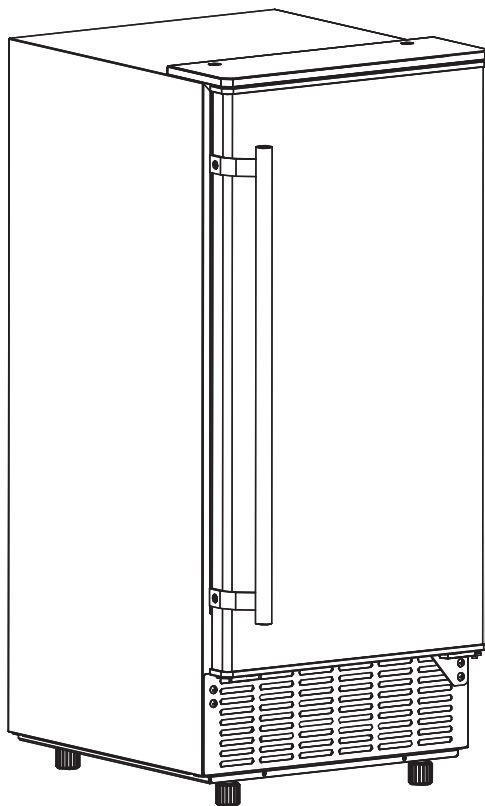

For Customer Service Support  
Call: 1-833-632-0897  
Email: [support@homyd.com](mailto:support@homyd.com)



## **Thank You for Choosing Our Product**

We sincerely thank you for choosing our product. Your trust and support are the greatest motivation for us to continuously refine our quality and improve our service.

If you have any suggestions during use or encounter any issues that require assistance, please feel free to contact us at [support@homyd.com](mailto:support@homyd.com). We value every piece of feedback and are committed to responding with sincerity and care.

Thank you once again.

We hope our product brings convenience and joy to your everyday life.

# Contents

Important Safety Instructions	02
Key Components and Structure	04
Detailed Component Descriptions	05
Control Panel and Display Overview	06
LCD Display Guide	07
Installation Guide	08
Cleaning Your Ice Maker Before Using for the First Time	13
Preparing Your Ice Maker for Long-Term Storage or Relocation	17
Clean Your Ice Maker	19
FAQs	21
Troubleshooting	24
Specifications	27
Warranty Policy	28

# IMPORTANT SAFETY INSTRUCTIONS

When using electrical appliances, basic safety precautions should be followed to reduce the risk of fire, electric shock, and injury to persons or property. Read all instructions before using any appliance.

1. Use this appliance only for its intended purpose as described in this owner's manual. This ice maker must be properly installed in accordance with the installation instructions before it is used.
2. This unit must be positioned so that the plug is accessible. **DO NOT** run the cord over carpeting or other heat insulators. **DO NOT** cover the cord or set anything on top of it. Keep the cord away from traffic areas. **DO NOT** submerge the cord in water.
3. No other appliance should be plugged into the same outlet. Be sure that the plug is fully inserted into the wall outlet.
4. We **DO NOT** recommend the use of an extension cord because it may overheat and cause a fire. If you must use an extension cord, use No. 14 AWG minimum size, rated no less than 1875 W.
5. If the supply cord is damaged, it must be replaced by the manufacturer, its service agent, or a similarly qualified person to prevent a hazard.
6. Unplug the unit when not in regular use, before cleaning or servicing it.

## WARNING

7. **DO NOT** clean your ice maker with flammable fluids. The fumes can create a fire hazard or an explosion.
8. This appliance must be grounded. Use the 110-120V/60Hz grounded power supply. Use the proper power source indicated on the nameplate.
9. Keep ventilation openings, either in the appliance enclosure or in the built-in structure, clear of obstructions.
10. This appliance is not intended for use by persons (including children) with reduced physical, sensory, or mental capabilities, or lack of experience and knowledge, unless they have been given supervision or instruction concerning use of the appliance by a person responsible for their safety.
11. Children should be supervised to ensure that they **DO NOT** play with the appliance.
12. **DO NOT** store explosive substances, such as aerosol cans with a flammable propellant, in this appliance.

- his appliance is intended to be used in commercial applications such as staff kitchen areas, in retail stores, offices, and other work environments. It might also be used by clients in hotels, motels, bed-and-breakfasts, and other residential-type environments, catering and similar non-retail applications, and farmhouses.

## **CAUTION**

- If for any reason this product requires service, we strongly recommend that a certified technician perform the service.
- Never unplug the unit by pulling on the power cord. Always grasp the plug firmly and pull it straight out from the outlet.
- DO NOT** use the unit outdoors. Keep it out of direct sunlight.
- Ensure there is at least 5cm (2 inches) of space between the back of your unit and the wall. Keep the front of the appliance clear of obstructions.
- DO NOT** tip the unit over as this will cause the machine to make unusual noises and produce abnormally sized ice cubes. Water leakage may also ensue.
- If the unit is stored in a cool or cold environment for some time, give it a few hours to warm up to room temperature before plugging it in.
- DO NOT** use liquids other than water to make ice cubes.

## **Risk of Fire or Explosion-Flammable Refrigerant Used**

Dispose of the appliance following federal or local regulations. Follow all handling instructions to ensure safe disposal.

**DO NOT** use mechanical devices to defrost the ice maker.

**DO NOT** puncture refrigerant tubing.

Servicing must be performed by trained personnel only.

The ice maker should comply with the safety standards for refrigeration systems (ASHRAE15) and should not be installed in corridors or hallways of public buildings.

Clean and maintain the appliance regularly according to the Cleaning & Maintenance section of this manual.

# KEY COMPONENTS AND STRUCTURE

- ① Door
- ② Ice-Making & its Water Reservoir Assembly  
Including ice-making evaporator, water reservoir, water pump and various detecting components.
- ③ Handle
- ④ Ice Bin
- ⑤ Control Panel
- ⑥ Air Outlet
- ⑦ Water Draining Port
- ⑧ Water Inlet Port for Water Supply

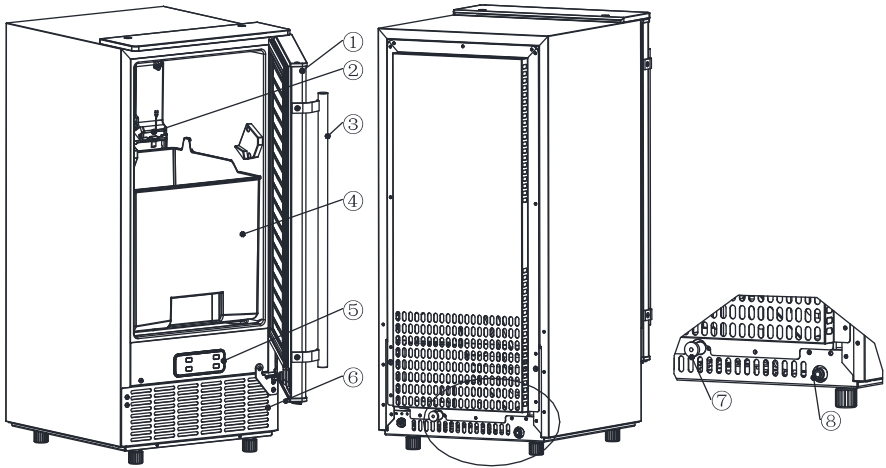

## Accessories

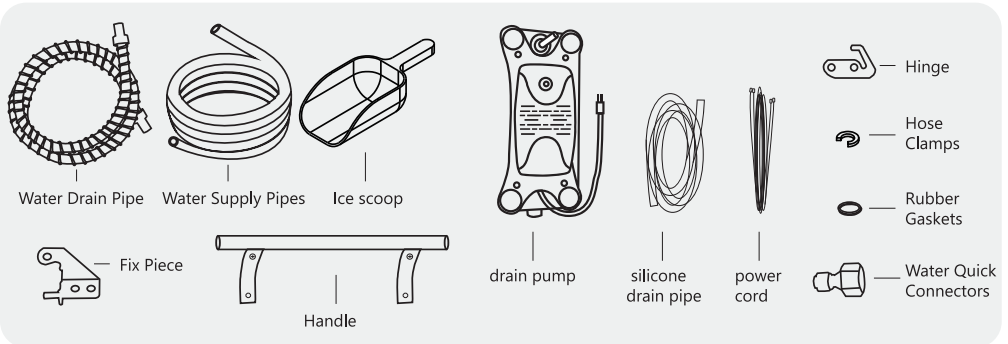

# DETAILED COMPONENT DESCRIPTIONS

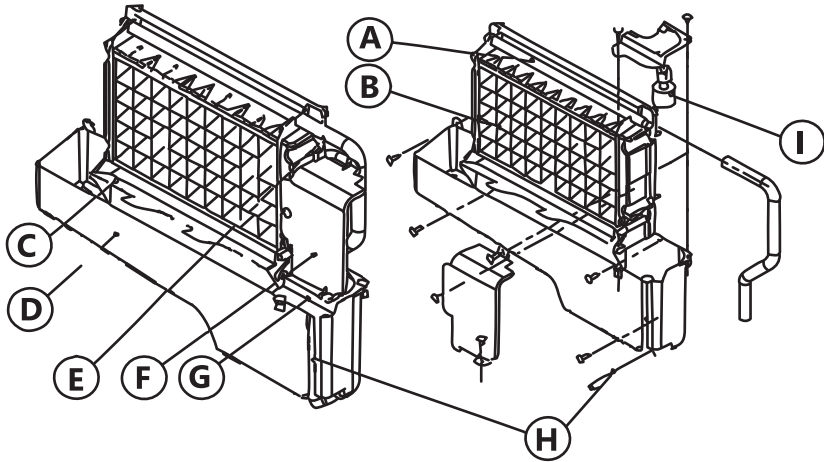

## **A. Water Dividing Pipe**

Equipped with nine small holes through which water flows. If no water flows out, the pipe can be disassembled and cleaned.

## **B. Evaporator (Ice-Making Module)**

### **C. Ice Full Detecting Board**

Detects whether the inner cabinet is full of ice and whether the ice-harvest process is complete. A magnet inside the hole on the right side of the ice-blocking plate helps it return to its original position.

### **D. Water Reservoir**

### **E. Water Supplying Pipe**

### **F. Cover Board on the Right Side of the Evaporator**

### **G. Water Level Switch Installing Plate**

### **H. Water Drain Pipe of the Water Reservoir**

When the unit is making ice, this pipe should be clamped into the slot on the water reservoir wall. For draining, the pipe should be removed from the slot.

### **I. Water Level Detecting Switch**

# CONTROL PANEL AND DISPLAY OVERVIEW

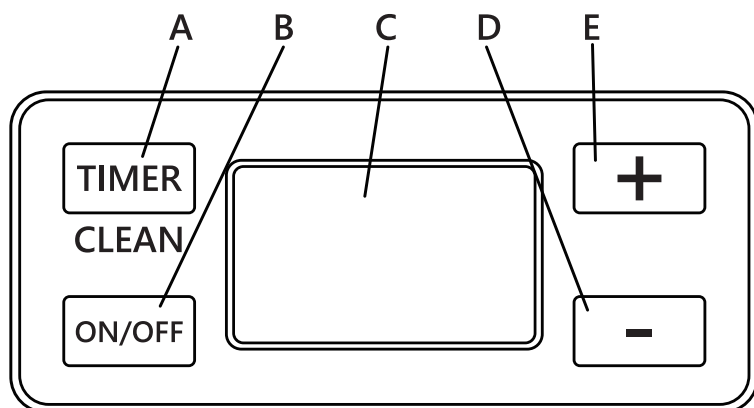

## TIMER/CLEAN Button

Press Once: Access the Timer Setting program.

Press and Hold (5+ Seconds): Start the Cleaning program.

## ON/OFF Button

Press once to turn on the machine when it is off.

Press once to turn off the machine when it is making ice or running in cleaning mode.

If a timer is set, press once to cancel the timer setting.

During the ice-making process, press and hold for 5 seconds to force the ice-harvesting process.

## "+" and "-" Buttons

Adjust Ice-Making Time: Press to increase or decrease by 1 minute per press.

Adjust Timer Delay: Press to increase or decrease by 1 hour per press.

Switch Temperature Units: Press and hold the "-" button for 5 seconds to toggle between Fahrenheit (°F) and Celsius (°C).

# LCD Display Guide

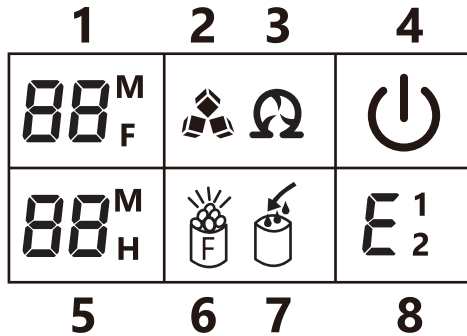

## 1. Environmental Temperature and Ice-Making Time Display

• The panel shows the ice-making time countdown in minutes (displayed as "M") and the environmental temperature in Fahrenheit (displayed as "F").

## 2. Ice-Making and Deicing Symbol:

- When the symbol rotates, the machine is making ice.
- When the symbol flashes, the machine is in the deicing process.

**3. Automatic Self-Cleaning Symbol:** Indicates the machine is in self-cleaning mode.

**4. Power On/Off Symbol:** The symbol lights up when the machine is on. If it flashes, the machine is in standby mode.

## 5. Error Code Display:

- E1: Environmental temperature sensor is damaged.
- E2: Ice-making malfunction or refrigerant leak detected.

## 6. Water Flow and Water Shortage Symbol

- A flashing arrow indicates water is flowing into the machine.
- A steady symbol indicates a water shortage.

## 7. Ice Full Alarm

- Alerts when the ice bin is full. Removing the ice restarts ice-making.

## 8. Settings Display

- **H (Timer):** 1-24H. In standby, press Timer and "+" to set start delay (e.g., "1H" = starts in 1 hour). During ice-making, press Timer and "+" to set stop delay (e.g., "1H" = stops in 1 hour).
- **M (Ice Thickness):** Adjust with "+" and "-" ("-6" = thinnest, "0" = default, "+6" = thickest).

# INSTALLATION GUIDE

## 1. Setup the Ice Maker

### A. Unpack and Inspect

Remove all exterior and interior packaging. Confirm all accessories are included: instruction manual, ice scoop, white water inlet pipe, 4-way to 2-way water quick connector, water draining pipe, etc. If anything is missing, contact our customer service. (email support@homyd.com or call us at +1-833-632-0897).

### B. Prepare the Ice Maker

Remove any tape securing the door, inner cabinet, and ice scoop. Clean the inner cabinet and ice scoop with a damp cloth. Install the door handle.

\*The protective film needs to be removed.

### C. Position the Ice Maker

Place the unit on a level, flat surface away from direct sunlight and heat sources (e.g., stove, furnace, radiator). Ensure a clearance of at least **25 cm (10 inches)** at the air outlet and allow **5 cm (2 inches)** of space at the back, top, and sides for proper air circulation. **DO NOT** place any objects on top of the ice maker.

### D. Allow Refrigerant to Settle

If the unit was tipped during shipping or transportation, let it sit upright for 24 hours to allow the refrigerant to settle before plugging it in.

### E. Plug Accessibility

Position the appliance so that the plug is easily accessible.

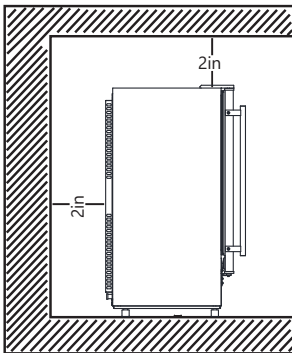

## Tips

1. This ice maker is not designed for outdoor use. Maintain the room temperature and inlet water temperature as specified to ensure optimal performance.
2. Follow the recommended spacing dimensions for adequate ventilation and to allow the unit to be pulled forward for servicing.
3. The ideal ambient temperature is between **10°C (50°F) and 32°C (90°F)**. Operating outside this range may affect performance or ice-making efficiency.
4. A continuous water supply with a pressure of 1-8 bar is required. The water temperature should be between **5°C (41°F) and 25°C (77°F)** for best results.

## 2. Reverse the Door Swing

*If you want the door to open from the opposite direction, you can reverse the door swing.*

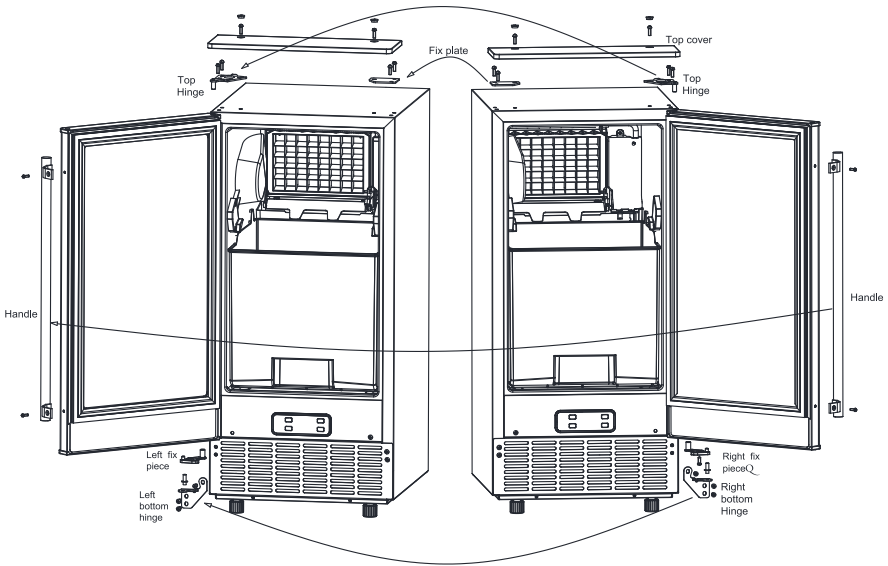

### A. Unplug the Power Cord

Before starting door reversal, ensure the unit is unplugged.

### B. Remove the Screws

Remove the 2 screw holes cover on the top cover, then unscrew the 2 screws that are fixed to the top cover.

Remove the 2 screws from the top hinge, and the 2 screws from the fix plate.

**C. Take Off the Door**

Lift the door up and remove it. Place the refrigerator door on a non-scratch surface with the exterior facing up.

**D. Install the Door on the Opposite Side**

a. Remove the two screws from the handle and attach it to the opposite side of the door.

b. Remove the screw from the right fixing piece and install the provided left fixing piece onto the door.

c. Remove the right bottom hinge by unscrewing the three screws, then reattach the screws without the hinge.

d. Remove the hinge pin from the right bottom hinge and reinstall it on the left bottom hinge.

e. Remove the 3 screws from the left side and fix the left bottom hinge on the unit.

f. Place the door on the left bottom hinge. With the magnetic gasket holding the door in place, make sure the door is aligned with the unit, and secure the top hinge on the left with 2 screws.

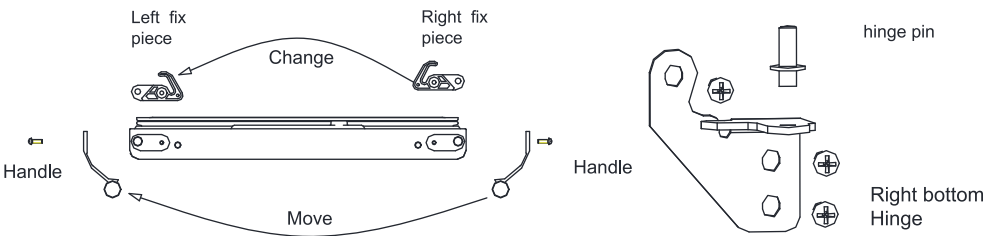

**E. Ensure the Position is Correct:** Open and close the door several times to confirm the door is positioned correctly and the gasket seals well. If this is not the case, please adjust the door again.

**F. Reset the Fix Plate:** Affix the fix plate back on the right side. Install the top cover with 2 screws, and cover the screw hole with the screw hole cover.

**G. Settle Down the Refrigerant:** Wait at least 30 minutes before plugging in the refrigerator to allow the refrigerant to settle down. Then plug in the unit.

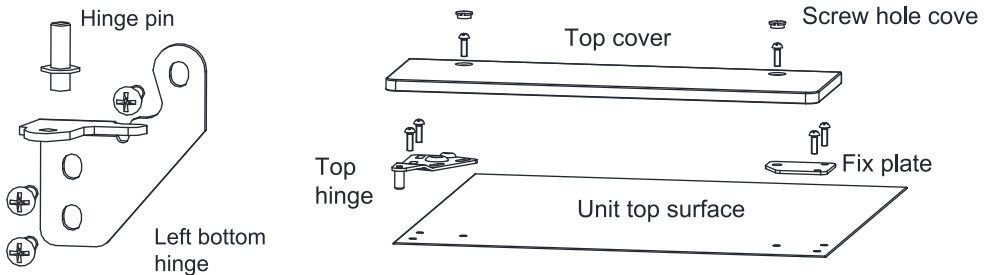

### 3. Connecting the Water Supply Hose

#### A. Prepare the Water Inlet Port

Locate the water inlet port for water supply at the back of the unit (marked as "B" in the illustration). Remove the clipper attached to the port by using one hand to press the outer circle of the port.

#### B. Attach the Water Hose

Insert one end of the white water hose firmly into the water inlet port, ensuring it is secure. Reattach the clipper to lock the hose in place. Your water supply connection is now complete.

### 4. Connecting the Water Drain Pipe

#### A. Prepare the Water Drainage Port

Locate the black-colored drainage cap (marked as "A" in the illustration). Remove it carefully.  
*\*Please ensure the drain pipe is lower than the water drainage port.*

#### B. Attach the Drain Pipe

Connect the provided grey water drainage pipe to the exposed drainage port. Ensure the other end of the pipe is securely connected to your main water drainage system.

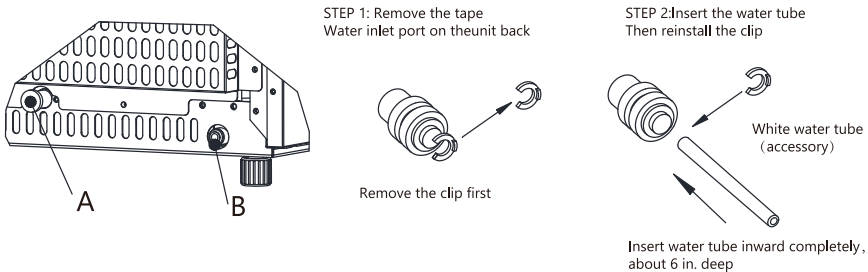

#### C. Attach the external water pump

The pump has two mounting slots at the ends. All four ports can connect to the ice maker gray water drain pipe. The central hole on one side is connected to the silicone drain line in the pump accessories. Ensure the pump is level.

After properly connecting the drainage pipe, the water pump is plug-and-play. You can first add water to the ice maker's ice bin for testing to check if the water pump is working. If not, please contact customer service for a replacement.

The pump should be installed in a location protected from splashing or spraying, and not inside air plenums.

## CAUTION:

The machine's drain outlet must be positioned higher than the entire drain pipe, including the external pump connection.

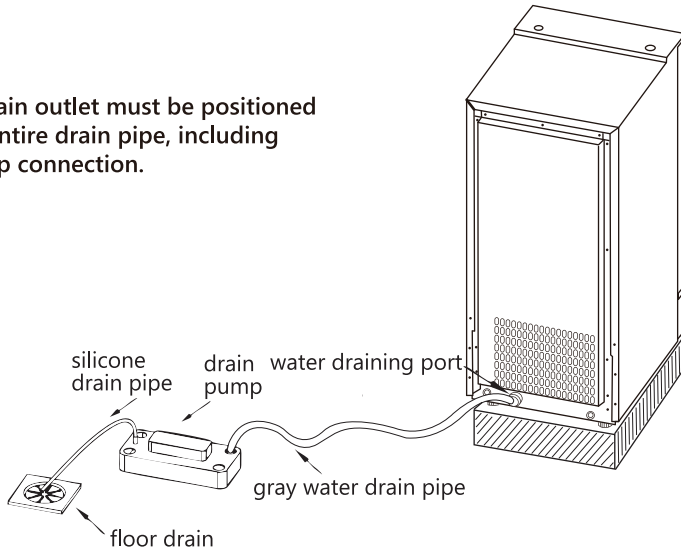

### A. Install the Quick-Connector

Attach the supplied quick-connector to the water faucet by screwing it on tightly.

### B. Connect the Water Hose

Remove the clipper from the quick-connector. Insert the free end of the water supply hose into the quick-connector port until it fits securely. Reattach the clipper to lock the connection in place.

**Important:** Ensure the water pressure of the main supply system is between 0.04 MPa and 0.6 MPa for proper operation.

*\* All drain pipe installation positions (including the connection with the external pump) must be lower than the drainage outlet, and the length of the drain pipes can be appropriately cut according to usage requirements.*

STEP 1: Quick-connector and the water faucet

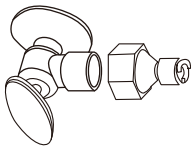

STEP 2: Screw the quick-connector on the water faucet by the screw thread, and remove the clipper

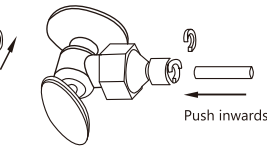
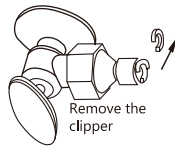

STEP 3: Insert the water hose completely

STEP 4: Install back the clipper

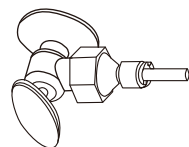

# CLEANING YOUR ICE MAKER BEFORE USING FOR THE FIRST TIME

## **Initial Cleaning**

Use a diluted detergent, warm water, and a soft cloth to clean the ice maker. Thoroughly clean all inner parts that come into contact with water.

*\*Please use a specialized ice machine cleaner for best performance. Avoid using harsh chemicals including alcohol, vinegar, or other acids, as they can damage the evaporator and shorten the life of the unit.*

## **Draining and Rinsing**

Pull the water drainpipe of the water reservoir to drain the clean water from the reservoir.

Clean the inner ice-storing cabinet and all inner parts until they are completely clean.

Drain the water from the water drain port located at the back of the unit.

## **Reassembly**

Reinstall the water drainpipe of the water reservoir. Failure to do so may result in the unit not making ice properly.

## **Final Step**

Dry both the interior and exterior of the ice maker with a clean, soft cloth.

## **Discard First Batch of Ice**

After cleaning, it is recommended to discard the ice cubes made during the first ice-making cycle.

# HOW TO OPERATE THE ICE MAKER

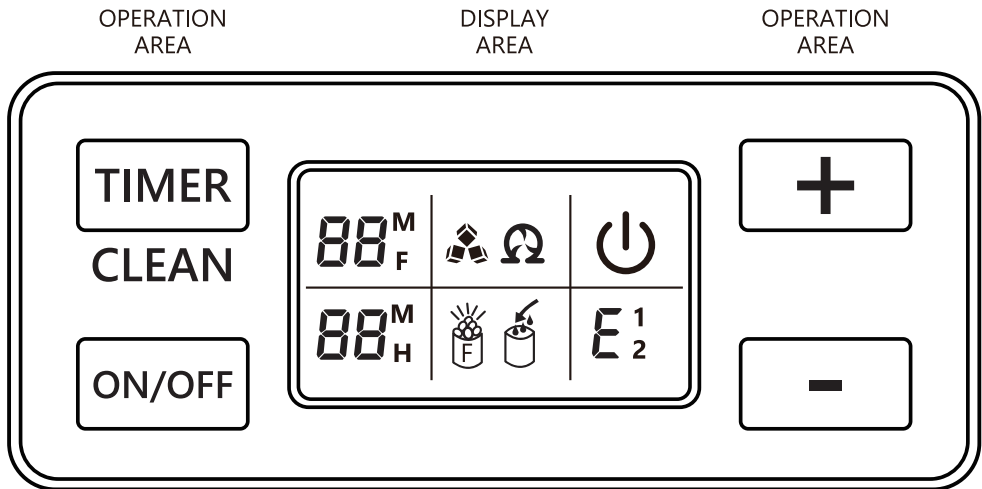



## 1. Starting Up the Unit

Plug in the power supply, and the  symbol will flash in the display window.

Press the **ON/OFF** button to start the machine.

The machine will begin making ice when the external pipe adds water to the reservoir, reaching the standard level via the electromagnetic water valve.



The  symbol will stay lit, and the Ice Making  symbol will rotate.

Ambient temperature is displayed in the upper-left corner of the display (e.g., 80F for 80°F).

A flashing number (e.g., 10M) indicates the remaining time (10 minutes) for the current ice-making cycle.

## 2. Ice-Making Process

### After every cycle:

- The machine enters the deicing process. The  symbol flashes, and the external pipe adds water to the tank via the electromagnetic valve.
- The arrow on the  symbol will flash until the water reaches the standard level.
- Once the standard level is met, the  symbol brightens, and the unit enters the next cycle.

### **If water does not reach the required level:**

- The  symbol lights up, and the unit stops working.
- After a water shortage, restart the unit manually, or it will restart automatically after 15 minutes.
- Each cycle takes approximately 11–20 minutes, depending on the ambient and water temperatures.
- The first cycle may take longer, but will not exceed 30 minutes.

## **3. Adjusting Ice Thickness**

- Use the "+" and "-" buttons on the control panel.
- "+" Button: Adds 1 minute to the ice-making time, making thicker ice.
- "-" Button: Reduces 1 minute from the ice-making time, making thinner ice.
- The default setting is "0." Restarting the machine resets it to the default.

When the  symbol lights up, the machine will stop operating.

Remove the ice to resume operation. Once the ice shield detects that the ice has dropped, it will automatically reset and start a new ice-making cycle.

## **5. Shutting Down the Unit**

- Press the **ON/OFF** button briefly to stop ice-making and enter standby mode.

## **6. Timer Settings**

**Range:** 1–24 hours.

### **Modes:**

- Time Shutdown: Set the unit to shut off after a specified duration.
- Time On: Set the unit to start automatically from standby mode.

### **How to Set a Timer:**

- Press the **TIMER** button (default is **1H**).
- Use the "+" or "-" buttons to adjust the time in 1-hour increments.
- After 5 seconds, the display stops flashing, and the timer is set.
- The "**H**" letter will change from flashing to always displaying, meaning the timer program has been completed.

**Schedule time:**

In standby mode, if "5H" is displayed, the machine will start automatically after 5 hours.

In ice-making mode, if "5H" is displayed, the machine will shut down automatically after 5 hours.

The "H" on the display indicates the machine's timer function. The number will gradually decrease until it reaches zero, at which point the machine will switch to the desired mode.

**How to Cancel the Timer:**

- When the panel displays "H," press the **TIMER** buttons briefly 2 times to cancel the timer.
- And the display "H" will be extinguished.

## 7. Automatic Self-Cleaning Program

**Default Cleaning Time: 20 minutes.**

**How to Start Self-Cleaning:**

- Connect the water pipes and plug in the power supply.
- Hold the **TIMER/CLEAN** button for more than 5 seconds when the unit is in standby.
- The  symbol rotates, and the countdown begins (e.g., 20M).
- The "CLEAN" light remains on, with the water pump running for 8 minutes and pausing for 3 minutes in cycles.

**How to Cancel Self-Cleaning:**

- The program ends automatically after 20 minutes.
- Press **ON/OFF** to cancel manually during cleaning.

## 8. Switching Temperature Units (°F to °C)

- Hold the "-" button for more than 5 seconds to toggle between Fahrenheit (°F) and Celsius (°C).

# PREPARING YOUR ICE MAKER FOR LONG-TERM STORAGE OR RELOCATION

If your ice maker will not be used for an extended period or if it needs to be moved to a different location, it's essential to prepare it correctly. Follow these steps:

## Step 1: Drain All Water

**Remove All Ice:** Empty the ice bin.

**Power Off:** Unplug the ice maker from the power source.

**Turn Off Water Supply:** Shut off the water supply to the ice maker.

**Disconnect Water Line:** Disconnect the water line connected to the ice maker.

**Drain Water Reservoir:** Locate the water reservoir drain and empty it completely.

**Drain Water Pump:** Drain any remaining water from the water pump and the drain pipe.

**Leave the Door Open:** Prop the door open to allow for air circulation and to prevent mold.

**Unplug Before Cleaning:** Always unplug the ice maker before cleaning.

**Avoid Harsh Chemicals:** Please use a specialized ice machine cleaner for best performance. Avoid using harsh chemicals, including alcohol, vinegar, or other acids, as they can damage the evaporator and shorten the life of the unit.

**Clean Condenser Coil:** Clean the condenser coil at least once a year to ensure optimal performance.

**Deep Clean After Storing:** If the ice maker has been sitting idle for a long time, give it a thorough cleaning before using it again.

## Step 3: Store Properly

**Dry Completely:** Ensure the ice maker is completely dry before storing.

**Cover:** Use a plastic bag to cover the ice maker, protecting it from dust.

### Daily Use Tips

**Ice Only:** Use the ice storage bin exclusively for ice. Avoid storing other items like bottles or cans.

**Mild Detergent:** When cleaning the exterior, use a mild detergent and warm water. Avoid abrasive cleaners.

**Stainless Steel Care:** If your ice maker has stainless steel components, clean them with a stainless steel cleaner and a soft cloth.

# CLEAN YOUR ICE MAKER

## Cleaning the Ice Bin

The ice storage bin should be sanitized before first use and after long periods of inactivity. It's best to clean it after the ice-making system has been cleaned and the bin is empty.

1. Disconnect power from the unit.
2. Open the door and, with a clean cloth, wipe down the interior with a sanitizing solution made of 1 ounce of household bleach and 2 gallons of hot water at **35-46°C(95-115°F)**.
3. Rinse thoroughly with clear water. The wastewater will flow out through the drainpipe.
4. Reconnect power to the unit.

**Caution: DO NOT** use solvent cleaning agents or abrasives on the interior. These cleaners may transmit taste to the ice cubes, or damage or discolor the interior.

## Cleaning the Ice Making Parts

1. **Disconnect power:** Unplug the ice maker.
2. **Clean the water reservoir and other parts:** Clean the water reservoir, water pump, and other internal parts. Pay special attention to the water dividing pipe on the evaporator. If water is not flowing through this pipe or the flow is very weak, carefully clean each small hole on the pipe to remove any blockages.
3. **Clean the evaporator:** If there is ice on the surface of the evaporator that won't fall off easily, turn on the ice maker and press the **"ON/OFF"** button for more than 5 seconds. This will melt the ice. Once the ice has melted, turn off the ice maker and unplug it. Clean the surface of the evaporator.

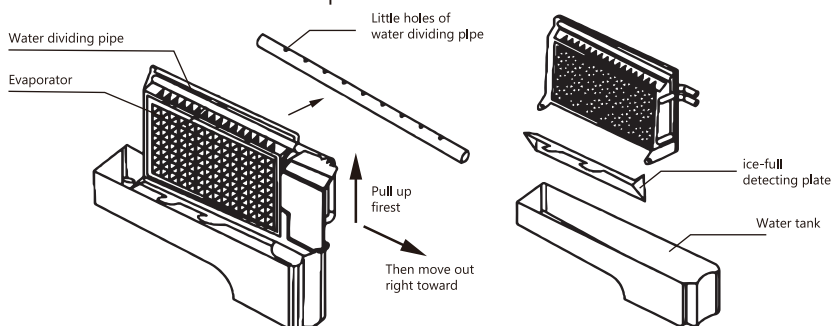

## Semi-Monthly Cleaning

Clean the ice scoop, ice bin, water reservoir, ice-full detecting plate, and the surface of the evaporator every two weeks. Follow the detailed cleaning instructions provided in the manual.

## Semi-Annual Cleaning

**Every 6 months**, deep clean all parts that come into contact with water or ice, including the ice storage bin, water reservoir, door, evaporator, water pump, and silicone tube. It is recommended to have a professional technician perform this cleaning.

### Note:

1. **Avoid harsh chemicals: Do not** use harsh chemicals or abrasive cleaners on any part of the ice maker. These can damage the surface and affect the taste of the ice.
2. **Regular cleaning:** For optimal performance, clean your ice maker regularly.
3. By following these simple steps, you can keep your ice maker clean and hygienic, ensuring that you always have a supply of fresh, clean ice.

## CORRECT DISPOSAL OF THIS PRODUCT



When the unit is taken out of service, its disposal and the handling of its materials must comply with national regulations.

## 1. How often should I clean my ice maker?

To ensure optimal performance, clean your ice maker at least once a week, depending on usage. Regular cleaning prevents scale buildup, which can block the pump and cause the machine to malfunction.

## 2. How do I clean the ice maker?

### Daily Cleaning

In standby mode, press and hold the "**TIMER**" button for 5 seconds to activate Cleaning Mode. Drain the water and return the drainage hose to its normal position.

### Deep Cleaning

Turn off the water supply and drain the tank. Dilute the nickel-protecting cleaner and pour it into the tank. Activate Cleaning Mode as before. After cleaning, drain, refill with fresh water, and run a few cycles. Discard the first batch of ice.

Note: Avoid acidic cleaners as they can corrode the evaporator. If necessary, unplug the machine, soak the tank for 30 minutes, then rinse with clean water. **DO NOT** wash the scoop in the dishwasher.

## 3. Why is water leaking from the machine?

Leaks may occur if the hole in the water distribution pipe is not straight down or the drain pipe is improperly connected. Here's what to check:

- Open the door and check that the hole in the water distribution pipe above the evaporator is facing downwards.
- Ensure the drain pipe is connected and positioned entirely below the drain outlet. The machine uses gravity drainage and includes a black drain plug at the port to prevent dust. For first-time use, move the plug and connect the drain pipe and external water pump. Keep it connected at all times to maintain smooth drainage. If you need assistance, contact [Support@homyd.com](mailto:Support@homyd.com).

## 4. Why do the ice cubes come out as a solid sheet instead of dropping as individual cubes?

We apologize if our product did not meet your expectations. The ice maker is designed to create ice in sheets rather than individually to enhance the efficiency of the ice-making process. We recommend reducing the ice-making time if the sheets are too thick or using the provided scoop to break the ice apart.

## 5. Why do my ice cubes melt quickly?

The ice maker does not have a refrigeration function. High ambient temperatures, especially in summer, can accelerate melting.

- Close the lid to maintain the internal temperature.
- Place a fan near the machine to disperse heat.
- For long-term storage, transfer ice cubes to a refrigerator.

## 6. What should I do if the ice-making is too slow or the ice cubes are too small?

Ice-making is too slow: Ice-making is slow at first use. Let it sit for 24 hours, then make ice several times at normal speed. Operate the ice maker in an environment below 90°F and use room temperature water for making ice.

Ice cubes are too small: In the first few cycles, the ice cubes might be smaller. Run several more cycles, and the ice will gradually return to its normal size.

## 7. Why is my ice too thick and difficult to release from the tray?

This may happen if the ice-making time is too long or if the room temperature is very low. We suggest unplugging the machine for 2 hours first, then plugging it back in and adjusting the ice thickness to “-6”.

To adjust ice thickness:

- Use the “+” and “-” buttons on the control panel.
- The number in the bottom-left corner of the display indicates the set ice-making time (default is 0).
- Press “+” to increase the time in 1-minute increments for thicker ice or “-” to reduce it for thinner ice.
- If you need assistance, contact the homyd team for a step-by-step video guide.

## 8. Why is there noise in the operation of my machine?

There is a faint sound when the machine is running. Closing the door can reduce the noise. If the water pump makes a noise during use, it is recommended to press and hold the “Timer” button for five seconds in standby mode to start self-cleaning mode first, and then turn on the machine to observe whether or not the noise disappears.

## **9.Does it make ice automatically and stop when the ice bin is full?**

Our ice maker is equipped with a sensor that automatically stops ice production when the ice bin is full.

## **10.Why is the ice maker white instead of stainless steel?**

The machine is made of stainless steel but comes with a white protective film to prevent scratches and fingerprints. If you prefer the stainless steel appearance, simply peel off the protective film.

## **11.Why are my ice cubes cloudy?**

The machine is made of stainless steel but comes with a white protective film to prevent scratches and fingerprints. If you prefer the stainless steel appearance, simply peel off the protective film.

## **12. Can I put milk or juice in the water tank?**

No, we strongly advise against this. High concentrations of milk or juice can clog the pump and shorten its lifespan. Additionally, milk proteins may calcify and react with the machine's internal PU water pipe, potentially causing damage.

## **13. Why does the ice cubes have a plastic smell?**

The ice cube itself has no taste. If you notice a plastic smell, try cleaning the inside of the machine with a neutral nickel-protecting cleaner, then run a few cycles, and finally rinse with distilled water. Discard the first batch of ice to ensure no cleaning solution residue remains.



## **14.Will the melted ice water in the ice basket be recycled?**

For hygiene and safety reasons, the melted ice that falls into the ice basket will be naturally drained by gravity. However, the water in the reservoir above the ice basket will be recycled to the evaporator until new ice is formed, so that no water is wasted.

# TROUBLESHOOTING

Problem	Possible Cause	Solution
Water is leaking.	Water sprays from the front.	Please adjust the angle of the water distribution pipe. We recommend that each hole of the water distribution pipe face downward, which can prevent water from splashing out and causing water leakage.
	Water flows out from the water tank.	Place the unit on a level surface, not on a slope. And jiggle the float up and down in the tank to check if it's stuck, and adjust it to the upside position.
	Water is leaking from the bottom.	This product provides an external water pump and operates on a gravity drainage design. Please ensure that the drain pipe and the external water pump is securely connected and positioned entirely below the drain outlet. If you need further assistance, contact our service team at support@homyd.com.
The ice-making cycle is normal, but no ice cubes are produced.	The temperature of the ambient, or water temperatures is too high.	Move to a place with a temperature lower than <b>32°C (90°F)</b> , and change to the low-temperature water.
	Insufficient refrigerant or a cooling system tube is clogged.	Press the "+" button to increase the ice-making time and adjust the thickness of the ice cubes to '+6' to check if the evaporator is still cold. If not cold, please contact our customer service team directly at support@homyd.com.

Problem	Possible Cause	Solution
There is water in the tank, but no water flows out from the water dividing pipe.	The water pump is blocked or broken.	Please contact our customer service team directly at support@ho-myd.com.
	The little holes in the water dividing pipe are blocked.	Clean the water distribution pipe and start self-cleaning once a week to extend product life.
There is a loud noise.	The motor makes intermittent noise when making ice.	Reposition the ice maker in other place and monitor its performance. If the issue persists, please contact our service team at support@ho-myd.com.
	Water is leaking from the bottom.	Unscrew the front panel screws, find the screws around the three front fans, and tighten them again. If the issue persists, please contact our service team at support@ho-myd.com.
Ice cubes are very thin.	Ambient temperature is too high.	Place in a cool area.
	Air circulation around the unit is not good.	Keep the vents unobstructed.
Ice cubes are too thick.	Ambient temperature is too low.	Please press the on/off button for more than 5 seconds until you hear the sound of the machine dropping ice. It takes 3-5 minutes for the ice cubes to fall. Reduce the ice-making time before the next ice-making cycle.
Ice cube shape is irregular.	The water quality is poor, the water tank is very dirty, and the ice cubes <b>DO NOT</b> fill the grid.	Change the water supply, or clean the water tank regularly.
	The little holes on the water dividing pipe are either blocked or not facing downward and aligned with the evaporator.	Clean and adjust the angle of the water distribution pipe. Make sure each hole is facing downward, and adjust the water pressure.

Problem	Possible Cause	Solution
<p>The unit start to enter the ice-making process, but no water is flowing in the tank, and "  " indicator flashes or is on.</p>	<p>No water supply.</p>	<p>Please check the main water supply pressure and ensure that the water supply hose is not blocked. You may need to increase the water pressure or clean the hose. If you still <b>DO NOT</b> have water, please contact our service team at support@homyd.com.</p>
	<p>The floating ball of the water level detecting switch is blocked and can't be raised.</p>	<p>Clean the water tank and the water level detecting switch.</p>
	<p>Water flows out of the hose on the right side of the water tank.</p>	<p>Install the hose back into the slot on the water tank correctly.</p>
<p>"  " indicator is on.</p>	<p>The ice storage bin is full of ice cubes.</p>	<p>Take out some ice cubes.</p>
<p>The transparency of the ice cube is not very good.</p>	<p>Water quality is not good.</p>	<p>Change the water supply, or use the water filter to soften or filter the water.</p>

# SPECIFICATIONS

CIM010-80 Commercial Ice Maker	
Specification	Value
Model	CIM010-80
Refrigerant	R290 2.65Oz/75g
Voltage/Frequency	115V/60HZ
Rated Ice-Making Power/Current	2.6A
Rated Ice Melting Power/Current	3.0A
Product Dimensions	20.19*14.96*33.9 inches
Net/Gross Weight	57.65/67.10lbs

# WARRANTY POLICY

## 1-Year Limited Warranty

**Toll-Free Call: 1-833-632-0897 Mon to Fri, 9AM - 6PM ( ET )**

**Email: [support@homyd.com](mailto:support@homyd.com)**

Thank you for choosing our products. We provide a 1-Year Limited Warranty for items purchased through our official channels. Please kindly note that this warranty is for the original purchaser and is non-transferable. If you purchase from an unauthorized seller, please get in touch with them directly.

We are committed to ensuring that our products are free from defects in materials and workmanship for one year from the date of purchase, as long as they are used under normal household conditions and maintained according to the User Manual. **Please note that certain conditions and exclusions apply:**

Should you find any defects in the original product or its non-wearable parts, we will be happy to repair or replace the item within one year of purchase. If a replacement is necessary, the warranty period will continue from the original purchase date. Please be aware that normal wear and tear, or damage due to mishandling, accidents, or failure to follow instructions, are not covered. However, replacement parts are available for purchase. Feel free to contact us for more information.

Please also note that this warranty does not cover damage caused by exposure to liquids or foreign materials, unauthorized repairs or modifications, or use in commercial or non-household environments (unless specified for commercial use).

If you encounter any issues with your product, we are here to help. You can reach us by phone at **1-833-632-0897** or email us at **[support@homyd.com](mailto:support@homyd.com)**. For certain product categories, we also offer the option to upgrade your warranty to our VIP service.

Our friendly phone support team is available from **Monday to Friday, 9 AM - 6 PM (ET).**- To assist you more efficiently, please have your product with you when you call. Besides, we aim to respond to emails within 24 business hours. If you don't receive a reply within this timeframe after sending us an email, kindly check your spam folder to ensure you don't miss our response.

In addition to the one-year warranty, we also offer lifetime technical support. After the warranty period, service is still available at an additional cost. Please don't hesitate to contact us with any questions or concerns.

SKU: CIM010-80BL-USZX

